

— —

一级代理商：

深圳市弗瑞鑫电子有限公司

地址：深圳市宝安区西乡大道302号金源商务大厦B座三楼

TEL：0755-29563634

FAX：0755-27447020

www.frxelec.com

1. Features

- () . % , ,
- - () . (,)
- ()
- -
- ,
-

2. Instructions

- -
- .
- ,

3. Application Range

- ().
- ().
- (). ,

4. Max Absolute rated Value (Normal Temperature=25)

	()		
*			
		- +	
		- +	
*			

* . , . . %

(1)

(2)

(3)

* .

5. Opto-electronic Characteristics(Normal Temperature=25)

Parameter	Symbol	Min	Typ.*	Max	Unit	Condition
Input		---	.	.		
		---		---		,
		---	---			, .
Output						

6. Rank table of current transfer ratio CTR

- Current Conversion Ratio = $I_C / I_F \times 100\%$

7. Order Information

Part Number

OR-3

8. Naming Rule

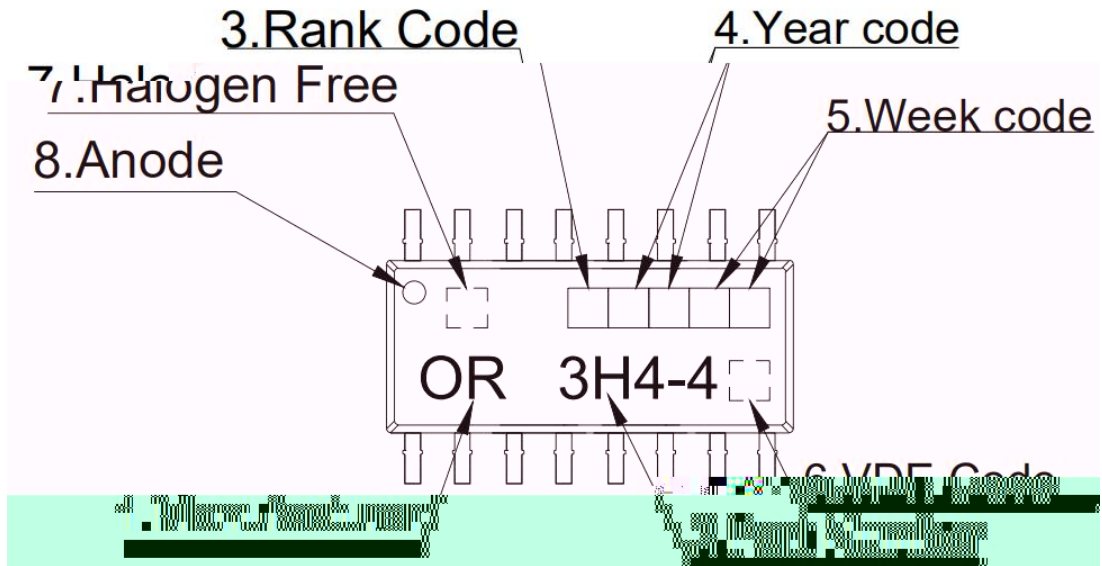

*
*

9. Outer Dimension

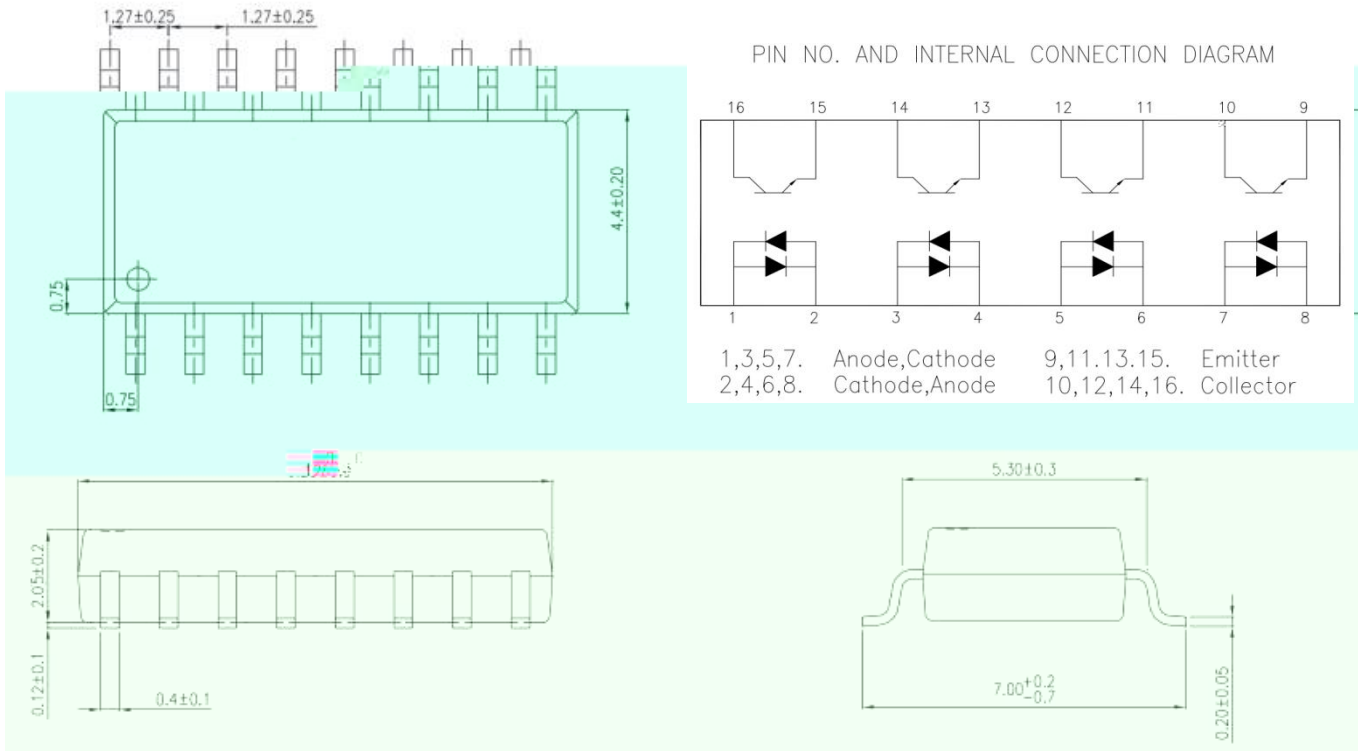

10. Recommended Foot Print Patterns (Mount Pad) (Unit:mm)

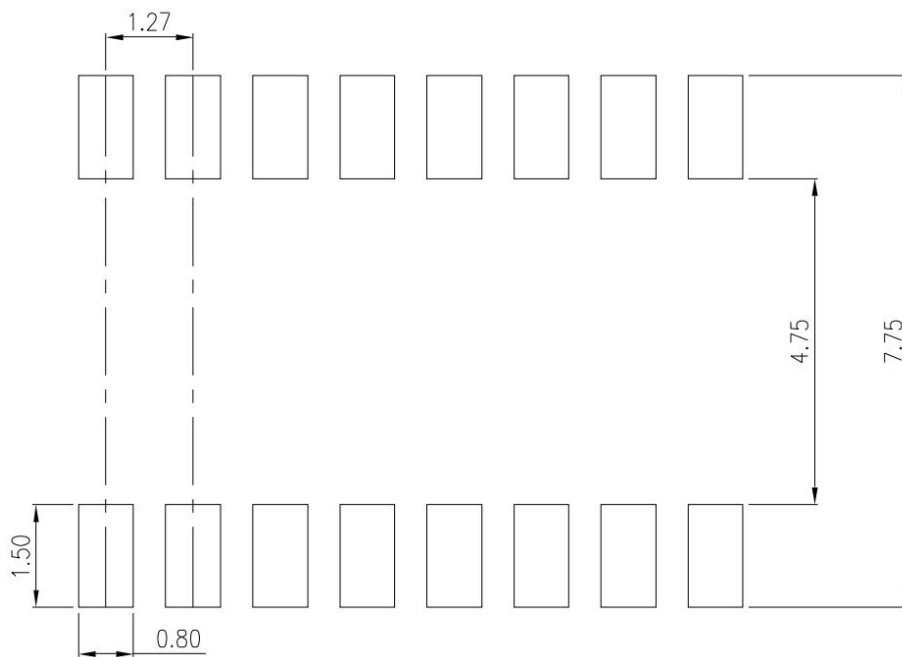

11. Taping Dimensions

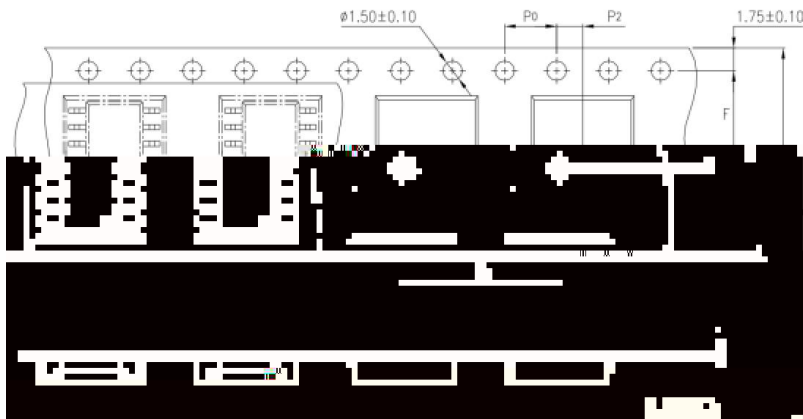
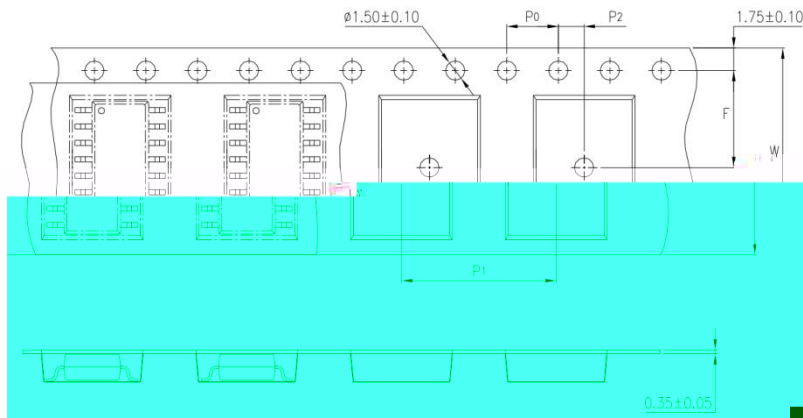

type	Symbol	Dimensions: mm (in.)
bandwidth h	W	16 ± 0.3 (0.47)
pitch	P_0	4 ± 0.1 (0.15)
pitch	F	7.5 ± 0.1 (0.217)
	P_2	2 ± 0.1 (0.079)
interval	P_1	12 ± 0.1 (0.315)

Encapsulation type	TA1/TA
Quantity (pieces)	2000

12. Package Dimension

Packing Information	
Packing type	Reel type
Tape Width	16mm
Qty per Reel	2000
Small box (inner) Dimension	345*345*60mm
Max qty per order	10000



1. MTL NO:Contents with "Order Information" in the specification.
2. LOT NO:The production cycle of the product.
3. BATCH:The CTR RANK of the product.
4. Quantity:Product packaging quantity.
5. Product Data: The data when product be made.

13. Reliability Test

NO.	[Redacted]	QTY. (Pcs)	Condition	Process	Standard
-----	------------	---------------	-----------	---------	----------

14. Temperature Profile Of Soldering

1 IR Reflow soldering (JEDEC-STD-020C compliant)

Profile item	Conditions
- ()	
- ()	
- () ()	
- ()	
- ()	

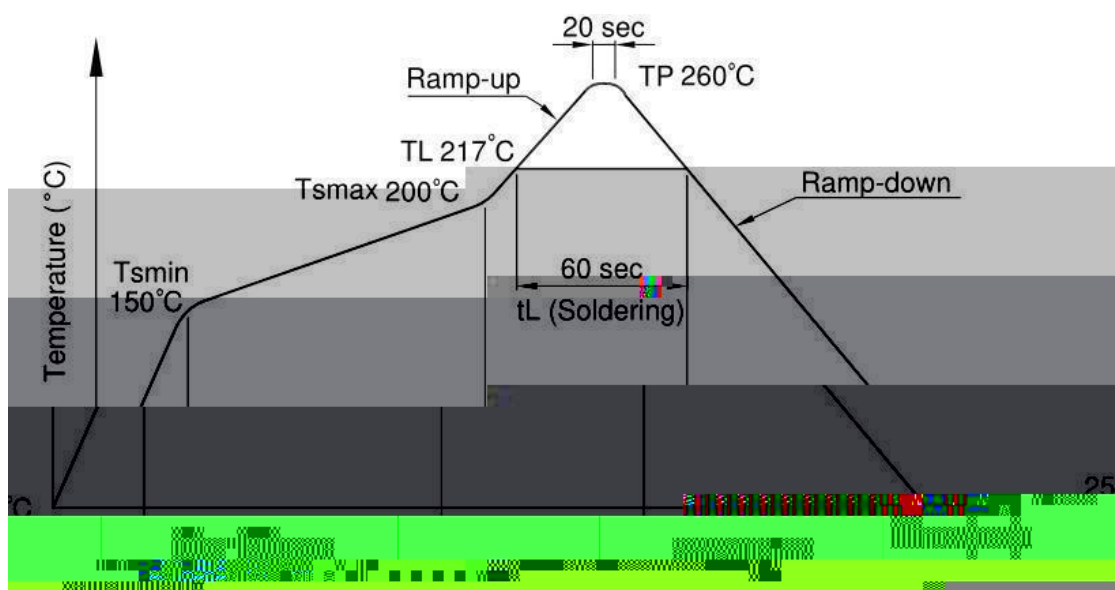

2 Wave soldering (JEDEC22A111 compliant)

	+ -

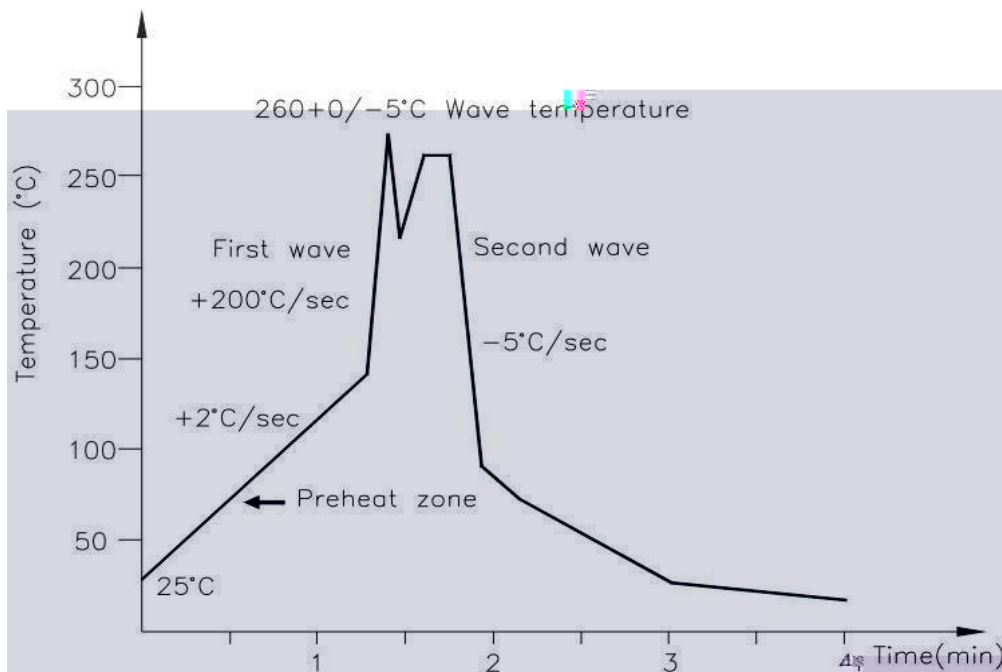

3 Hand soldering by soldering iron

Temperature	380+0/-5°C
Time	3 sec max

15. Characteristics Curve

Figure 1. Collector Power Dissipation vs. Ambient Temperature

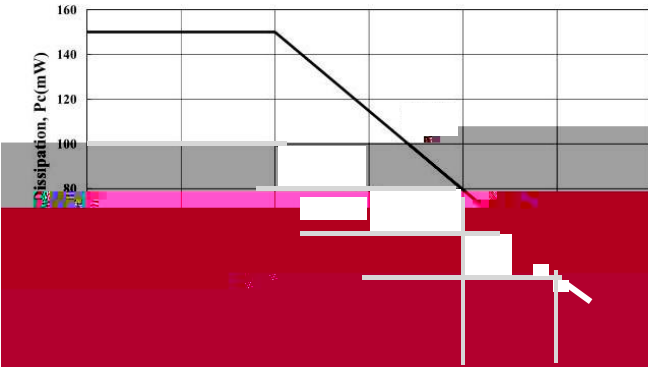

Figure 2. Forward Current vs. Ambient Temperature

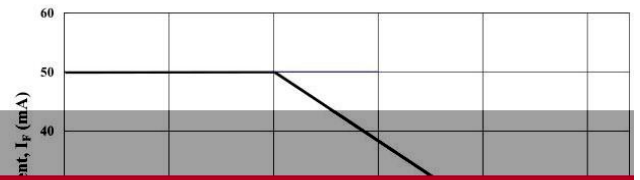

Figure 3. Forward Current vs. Forward Voltage



Figure 4. Forward Voltage Temperature Coefficient vs. Forward Current



Figure 5. Pulse Forward Current vs. Duty Cycle Ratio

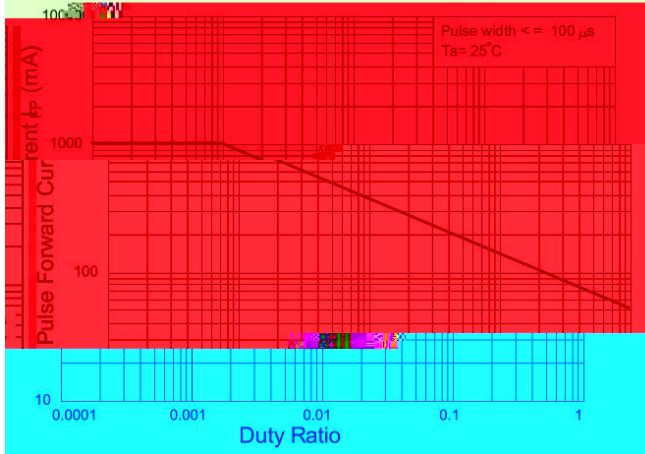

Figure 6. Pulse Forward Current vs. Pulse Forward Voltage

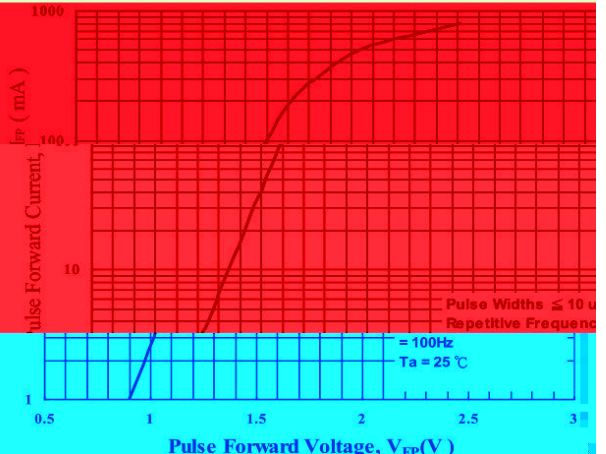

Figure 7. Collector-Emitter Saturation Voltage vs. Forward

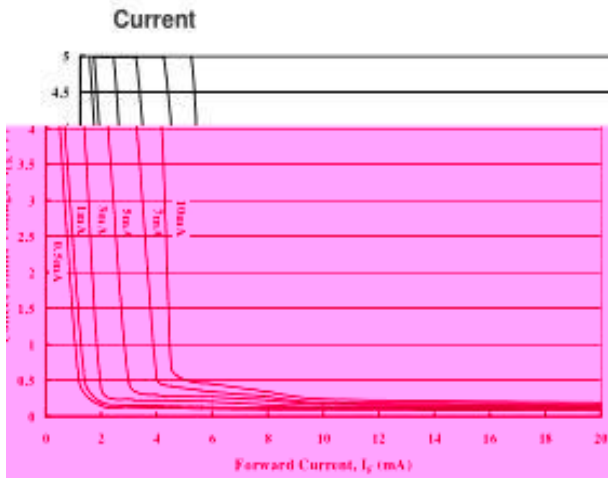

Figure 8. Collector Current vs. Collector-Emitter

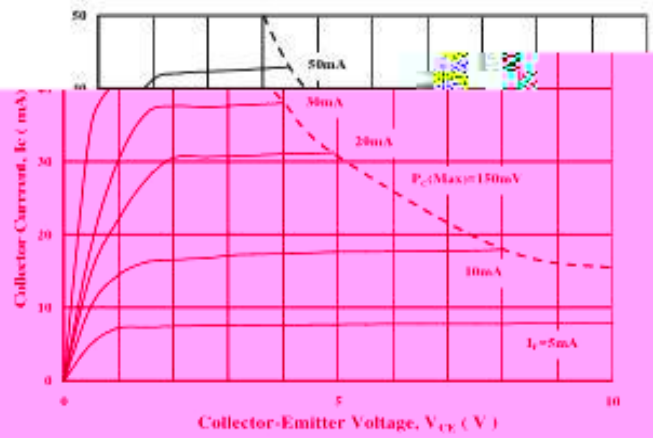

Figure 9. Collector Current vs. Small Collector-Emitter

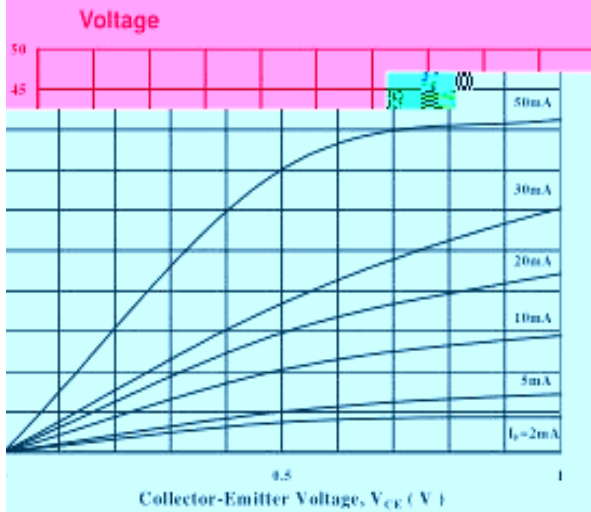

Figure 10. Normalized CTR vs. Forward

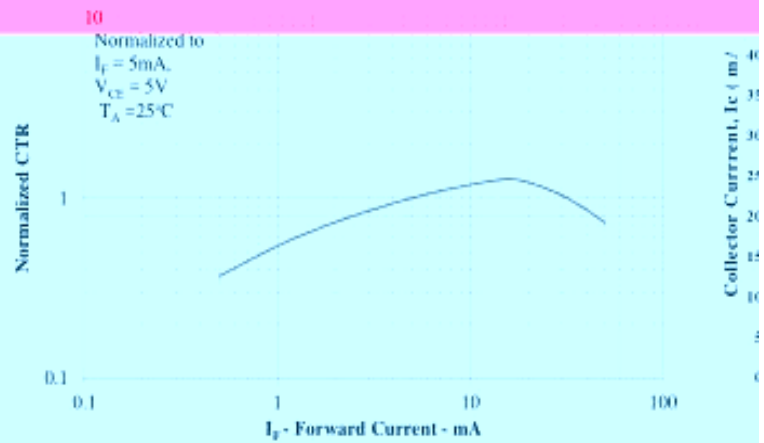

Figure 11. Collector Dark Current vs. Ambient Temperature

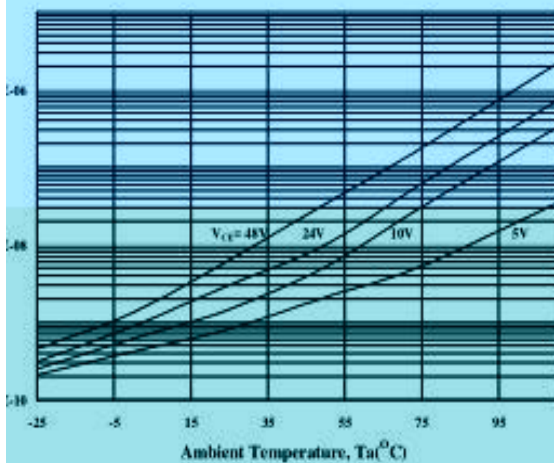

Figure 12. Current Transfer Ratio vs. Forward

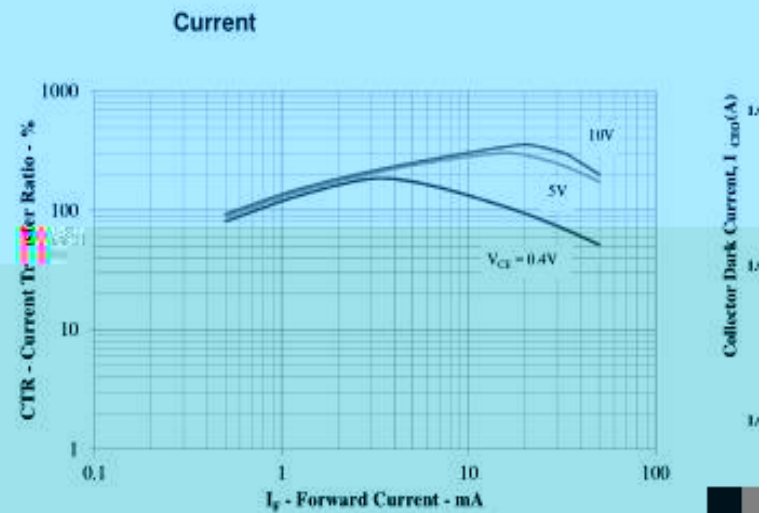

Figure 13. Normalized CTR vs. f_c

