

# SB5560S 55A<sup>+</sup>SCRs

## FEATURES

- High thermal cycling performance
- High voltage capacity
- Very high current surge capability

## APPLICATIONS

- Line rectifying 50/60 Hz
- Softstart AC motor control
- DC Motor control
- Power converter
- AC power control
- Lighting and temperature control

## Parameters Summary

VD/VR:1200/1600V IT(RMS):55A IGT :60mA

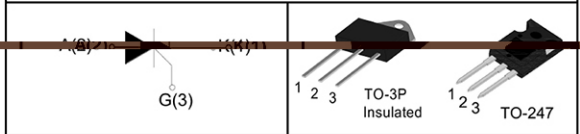

ABSOLUTE MAXIMUM RATINGS				
Parameter	Symbol	value	Unit	
Storage junction temperature range	Tstg	-40~150	°C	
Operating junction temperature range	Tj	-40~125	°C	
Repetitive peak off-state voltage (T=25°C)	V <sub>DRM</sub>	1200/1600	V	
Repetitive peak reverse voltage (T=25°C)	V <sub>RRM</sub>	1200/1600	V	
Non repetitive surge peak Off-state voltage	V <sub>DSM</sub>	V <sub>DRM</sub> +100	V	
Non repetitive peak reverse voltage	V <sub>RRM</sub>	V <sub>RRM</sub> +100	V	
RMS on-state current	TO-3PIns.(TC=80°C)	I <sub>T(RMS)</sub>	55	A
	TO-247(TC=85°C)			
Non repetitive surge peak on-state current	I <sub>TSM</sub>	550	A	
Average on-state current (180° conduction angle)	I <sub>T(AV)</sub>	35	A	
I <sup>2</sup> t value for fusing (tp=10ms)	I <sup>2</sup> t	1500	A <sup>2</sup> S	
Critical rate of rise of on-state current (I=2×IGT, tr ≤ 100 ns)	di/dt	150	A/μS	
Peak gate current	I <sub>GM</sub>	5	A	
Average gate power dissipation	P <sub>G(AV)</sub>	2	W	

Thermal Resistances				
Symbol	Parameter	Value	Unit	
Rth(j-c)	Junction to case (DC)	TO-3P	0.65	°C/W
		TO-247	0.60	

ELECTRICAL CHARACTERISTICS (T=25°C unless otherwise specified)				
Symbol	Test Condition		Value	Unit
$I_{GT}$	$V = 12V$ $R = 140\Omega$	MAX.	60	mA
$V_{GS}$		MAX.	1.3	V
$V_{GD}$	$V_D = V_{DRM}$ $T_J = 125^\circ C$	MIN.	0.2	V
$I_L$	$I_G = 1.2I_{GT}$	MAX.	250	mA
$I_H$	$I_T = 50mA$	MAX.	200	mA
dV/dt	$V_D = 2/3V_{DRM}$ Gate Open $T_J = 125^\circ C$	MIN.	1000	V/ $\mu s$

STATIC CHARACTERISTICS				
Symbol	Parameter		Value(MAX.)	Unit
$V_{TM}$	$I_{TM} = 30A$ $t_{ON} = 100\mu s$	$T_J = 25^\circ C$	1.0	V
$I_{DRM}$	$V_D = V_{DRM}$ $V_R = V_{RRM}$	$T_J = 25^\circ C$	20	$\mu A$
$I_{RRM}$		$T_J = 125^\circ C$	8	mA

### Ordering information Scheme

# SB 55 60 - 16 M S

LOGO

IT(RMS):55A

$I_{GT}: 60mA$

VD/VR:1200/1600V

M:TO-3P N:TO-247

Standard SCR series

### TO-3P Package Mechanical Data

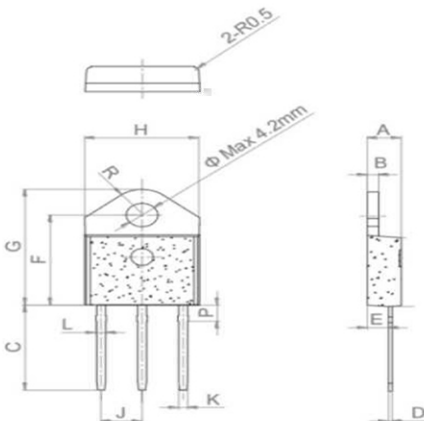

Ref.	Dimensions					
	Millimeters			Inches		
	Min.	Typ.	Max.	Min.	Typ.	Max.
A	4.00	4.00	4.00	0.157	0.157	0.157
B	1.40	1.60	1.60	0.055	0.062	0.062
C	15.48	15.88	15.88	0.609	0.625	0.625
D	0.50	0.70	0.70	0.020	0.028	0.028
E	2.70	2.90	2.90	0.106	0.114	0.114
F	15.92	16.32	16.32	0.626	0.642	0.642
G	20.27	20.67	20.67	0.798	0.813	0.813
H	15.15	15.35	15.35	0.590	0.604	0.604
J		5.45			0.214	0.216
K	1.10	1.30	1.30	0.043	0.051	0.051
L	1.15	1.35	1.35	0.045	0.053	0.053
P	2.68	3.08	3.08	0.105	0.121	0.121
R		4.20			0.165	0.165

## TO-247 Package Mechanical Data

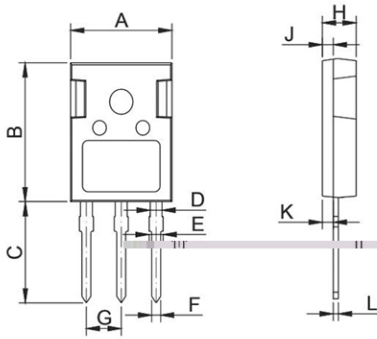

Ref.	Dimensions					
	Millimeters			Inches		
	Min.	Typ.	Max.	Min.	Typ.	Max.
A	15.50	15.80	16.30	0.610	0.622	0.634
B	20.80	21.00	22.20	0.810	0.828	0.874
C	19.70	20.00	20.30	0.776	0.787	0.799
D	1.80	2.00	2.20	0.071	0.079	0.087
E	1.90	2.10	2.30	0.075	0.083	0.091
F	1.00	1.20	1.40	0.039	0.047	0.055
G		5.44			0.214	
H	4.80	5.00	5.20	0.189	0.197	0.205
J	1.90	2.00	2.10	0.075	0.079	0.083
K	2.20	2.35	2.50	0.087	0.093	0.098
L	0.41	0.60	0.79	0.016	0.024	0.031

FIG.1 Maximum power dissipation versus on-state current

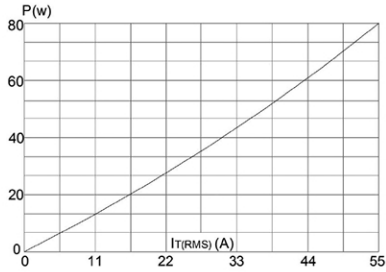

FIG.2: on-state current versus case temperature

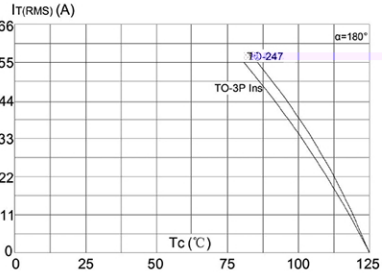

FIG.3: Surge peak on-state current versus number of cycles

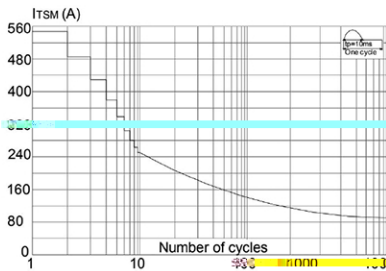

FIG.4: On-state characteristics (maximum values)

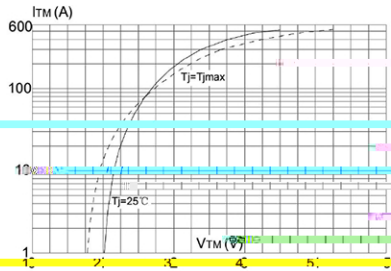

FIG.5: Non-repetitive surge peak on-state current for a sinusoidal pulse with width  $t_p < 10\text{ms}$ , and corresponding value of  $12 t$

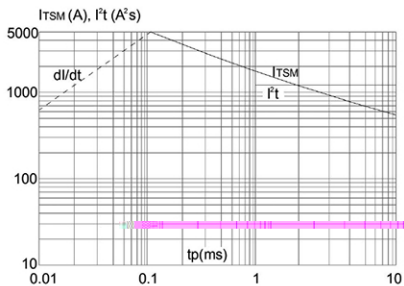

FIG.6: Relative variation of gate latching current versus junction temperature

