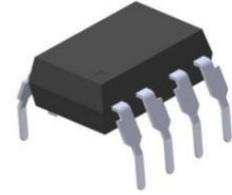
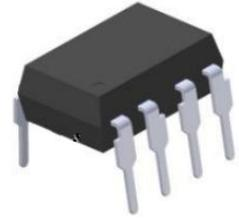

一级代理商：

深圳市弗瑞鑫电子有限公司

地址：深圳市宝安区西乡大道302号金源商务大厦B座三楼

frxelec

1. Features



2. Instructions

3. Application Range

-
-
-
-

4. Functional Diagram

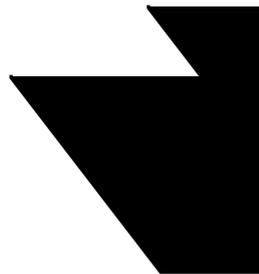
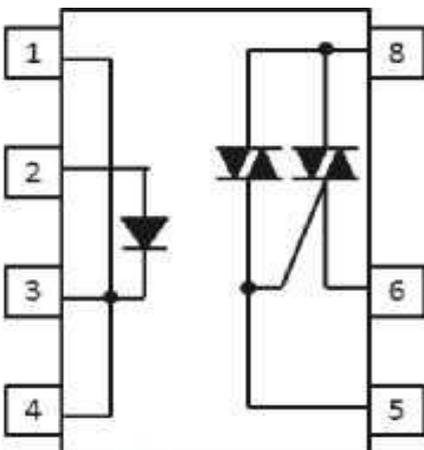

5. Absolute Maximum Ratings (Ta=25°C)

| Parameter | | Symbol | Rated Value | Unit |
|-----------|--|--------|-------------|------|
| | | | | |
| | | | | |
| | | | | |
| | | | | |
| | | | | |
| | | | | |
| | | | | |
| | | | | |
| | | | | |
| | | | | |
| | | | | |
| | | | | |
| | | | | |
| | | | | |
| | | | | |
| | | | | |
| | | | | |

*

6. Recommended Operating Conditions

| Parameter | | Symbol | Min | Typ.* | Max | Unit | Condition |
|--------------------------|--|--------|-----|-------|-----|------|-----------|
| Input | | | | | | | |
| | | | | | | | |
| Output | | | | | | | |
| | | | | | | | |
| | | | | | | | |
| | | | | | | | |
| Transfer Characteristics | | | | | | | |
| | | | | | | | |
| | | | | | | | |

7. Order Information

Part Number

OR-X223U-Y-Z

Note

| Option | Description | Packing quantity |
|---------------|--------------------|-------------------------|
| | | |
| | | |
| | | |
| | | |

8. Naming Rule

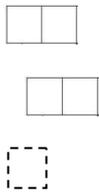
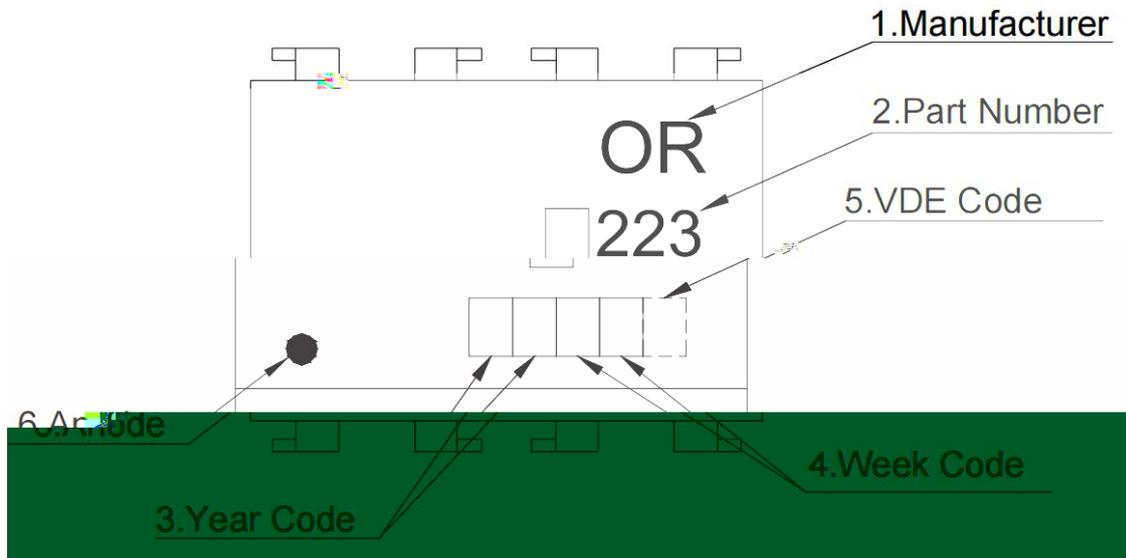

9. Outer Dimension

1 OR-X223

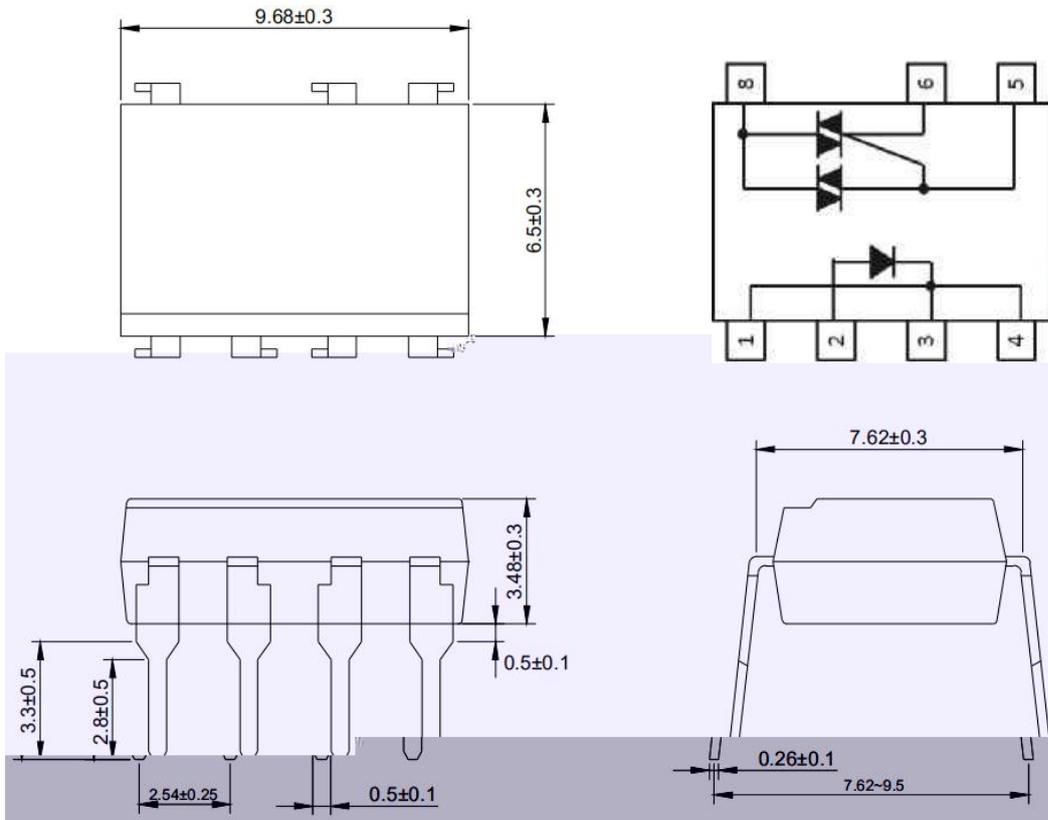

2 OR-X223M

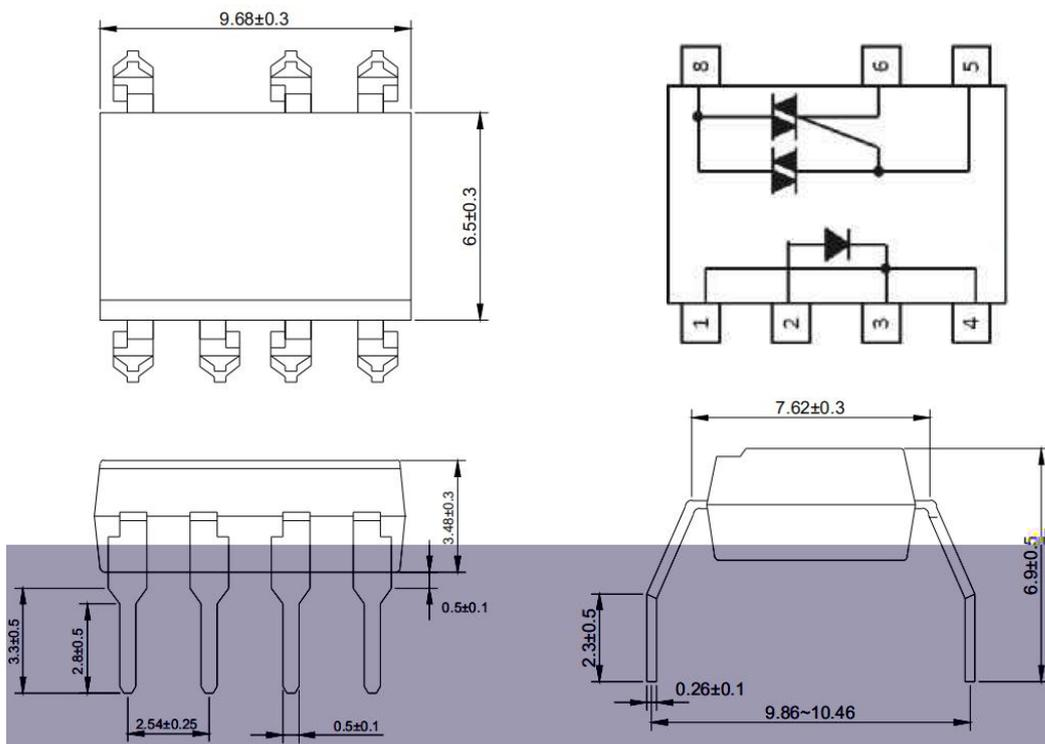

3 OR-X223S

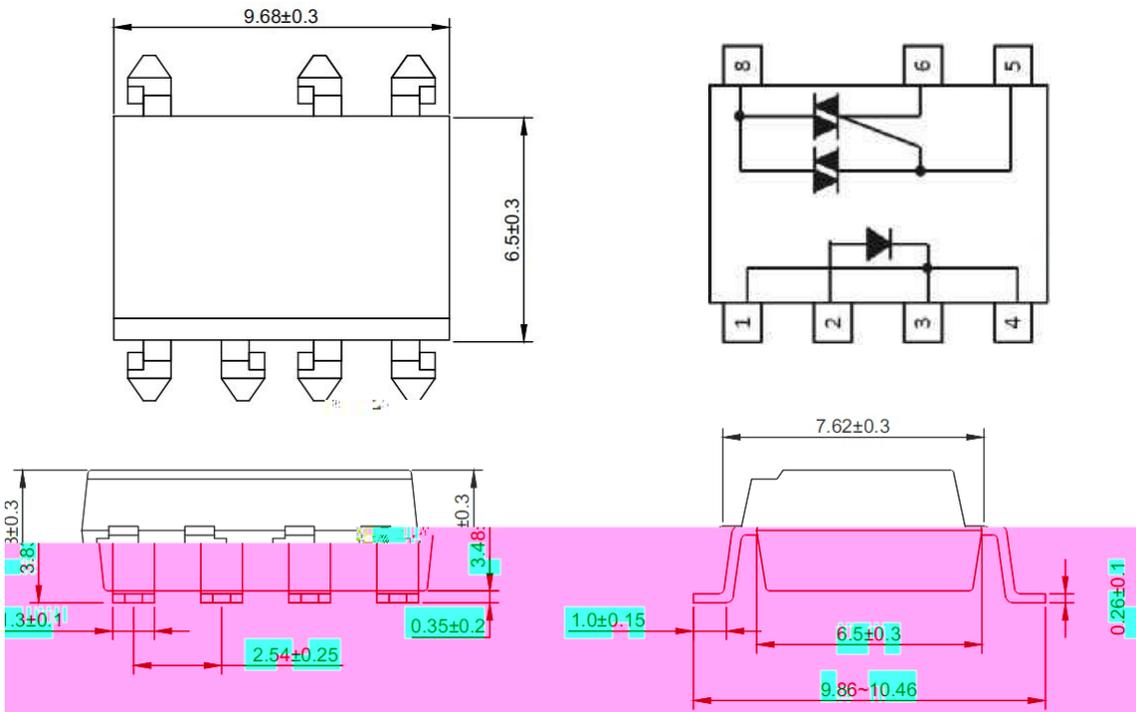

12 Recommended Foot Print Patterns (Mount Pad)

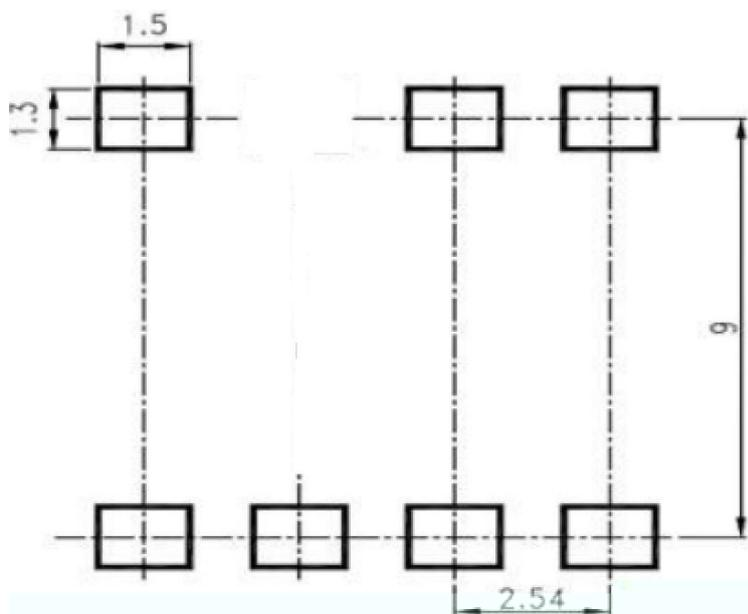

10. Taping Dimensions

1 OR-X223-TA

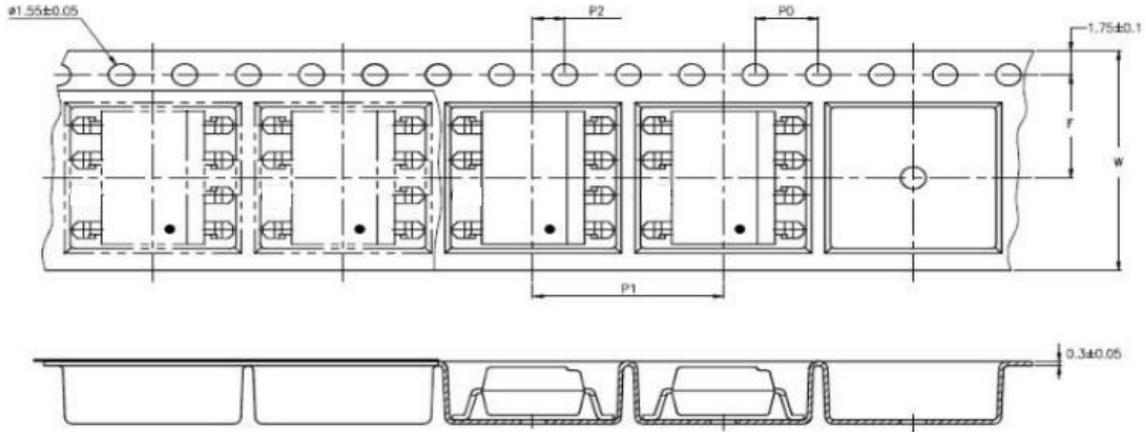

2 OR-X223-TA1

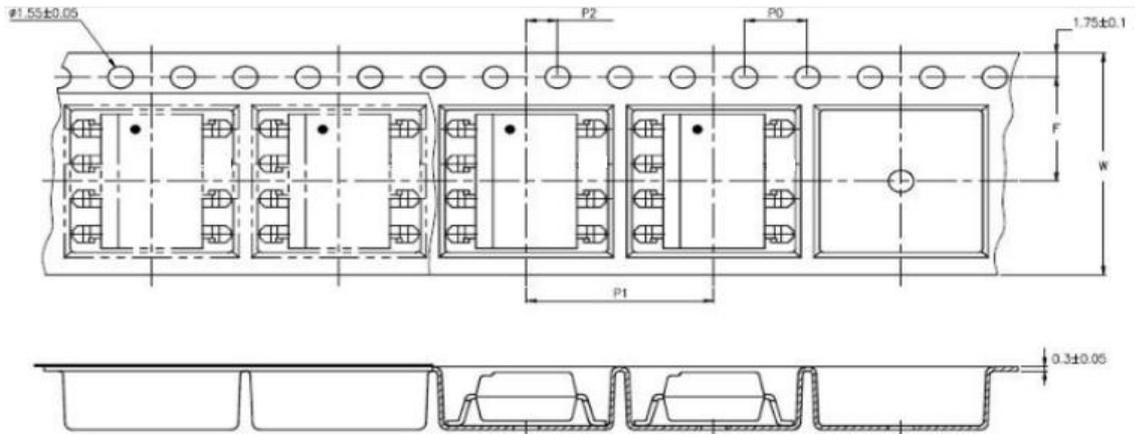

| | | |
|--|--|--|
| | | |
| | | |
| | | |
| | | |
| | | |
| | | |

| | |
|--|--|
| | |
| | |

| | |
|--|--|
| | |
| | |

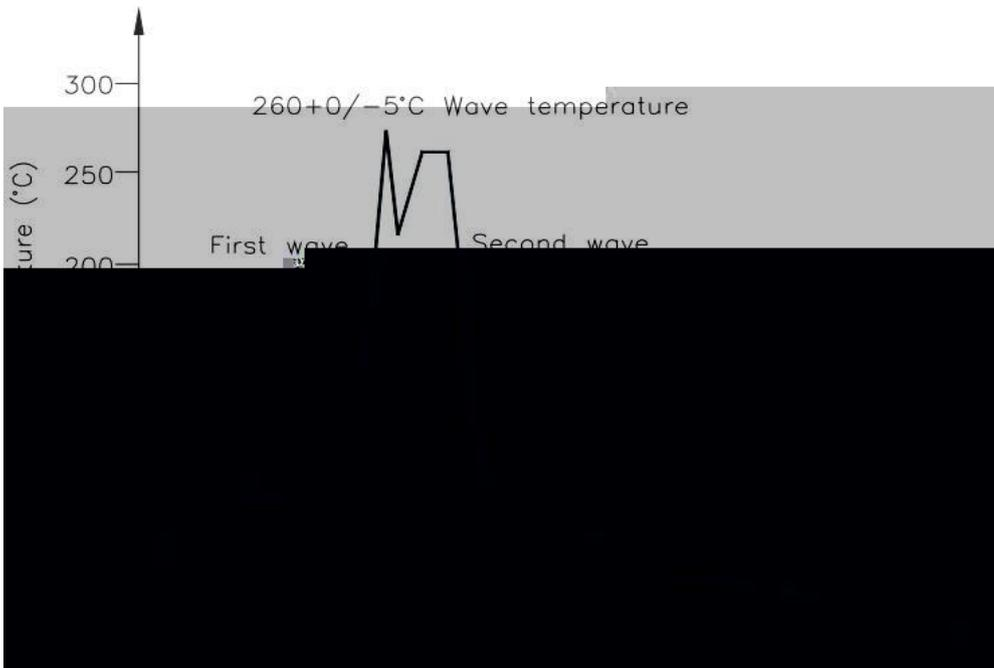

| | |
|--|--|
| | |
|--|--|

13. Characteristics Curve

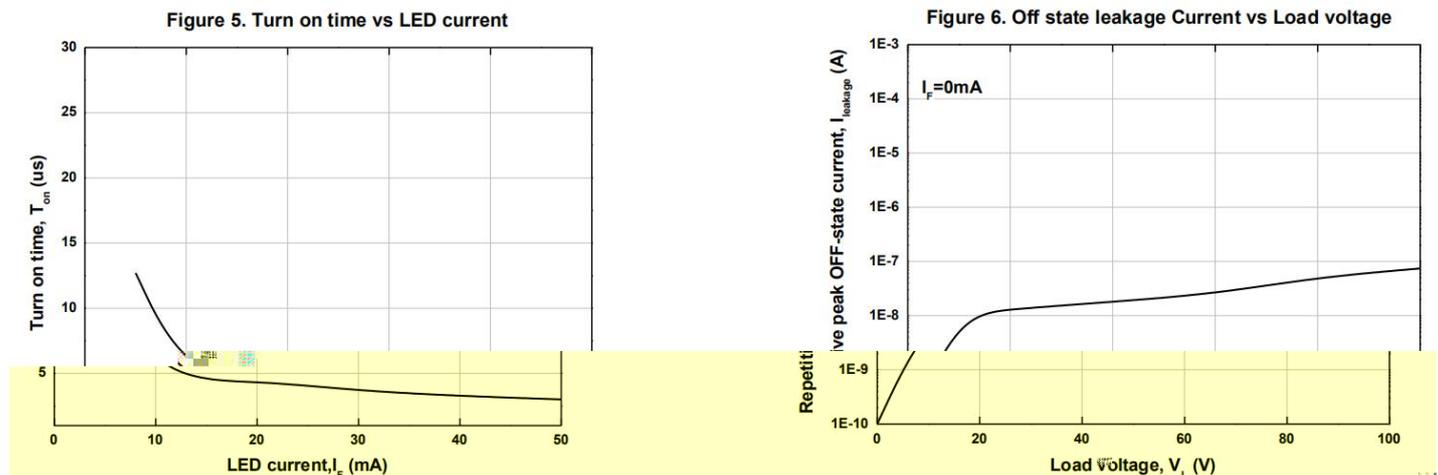
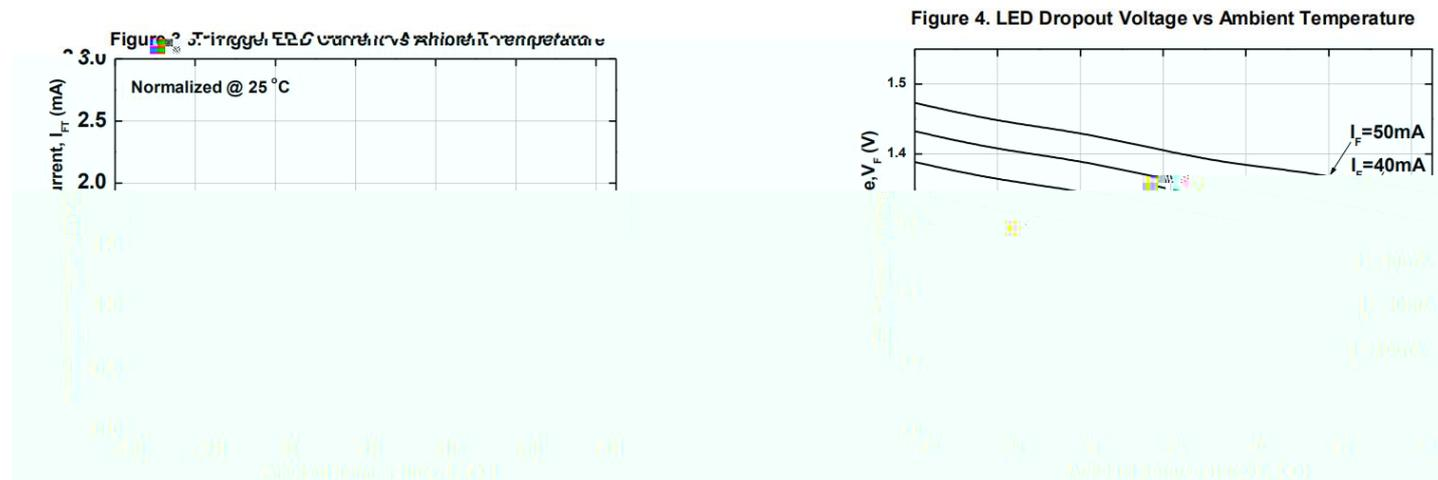
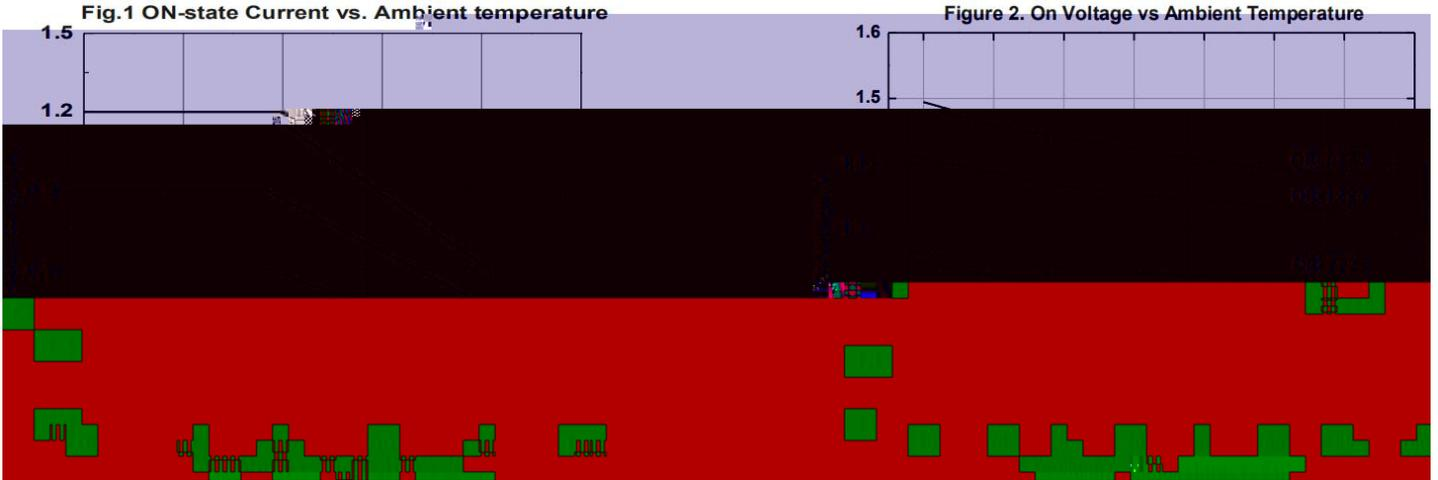

Figure 7. Holding Current vs. Ambient Temperature

